



6DEPLOY

IPv6 Protocol (headers & options)

6DEPLOY. IPv6 Deployment and Support

Copy ...Rights

This slide set is the ownership of the 6DISS project via its partners

The Powerpoint version of this material may be reused and modified only with written authorization

Using part of this material must mention 6DISS courtesy

PDF files are available from www.6diss.org

Looking for a contact ?

- ***Mail to : martin.potts@martel-consulting.ch***
- ***Or bernard.tuy@renater.fr***



Droits d'auteur ...

L'ensemble des présentations utilisées dans le cadre de cet atelier est la propriété de 6DISS, représenté par ses différents partenaires.

La version Powerpoint des présentations peut être réutilisée et modifiée après qu'une autorisation écrite ait été obtenue

L'usage de tout ou partie de ce matériel doit mentionné que sa source est le projet 6DISS

La version PDF des présentations est disponible sur www.6diss.org

Pour tout contact :

- *Mail à Martin.Potts@martel-consulting.ch*
- *Ou Bernard.Tuy@renater.fr*

Contribs

B. Tuy, RENATER

L. Toutain, ENST-B



Updates

B. Tuy 20/05/2008



Agenda

IPv6 Header

- Comparison with IPv4

IPv6 optional headers (extensions)

Processing IPv6 headers

- Comparison with IPv4



IPv6 Header

The IPv6 header is designed

- To minimize header overhead
- and reduce the header process for most of the packets
- Less important information and option fields are moved to *extension headers*

⇒ **IPv6 & IPv4 headers are not interoperable**

IPv4 Header

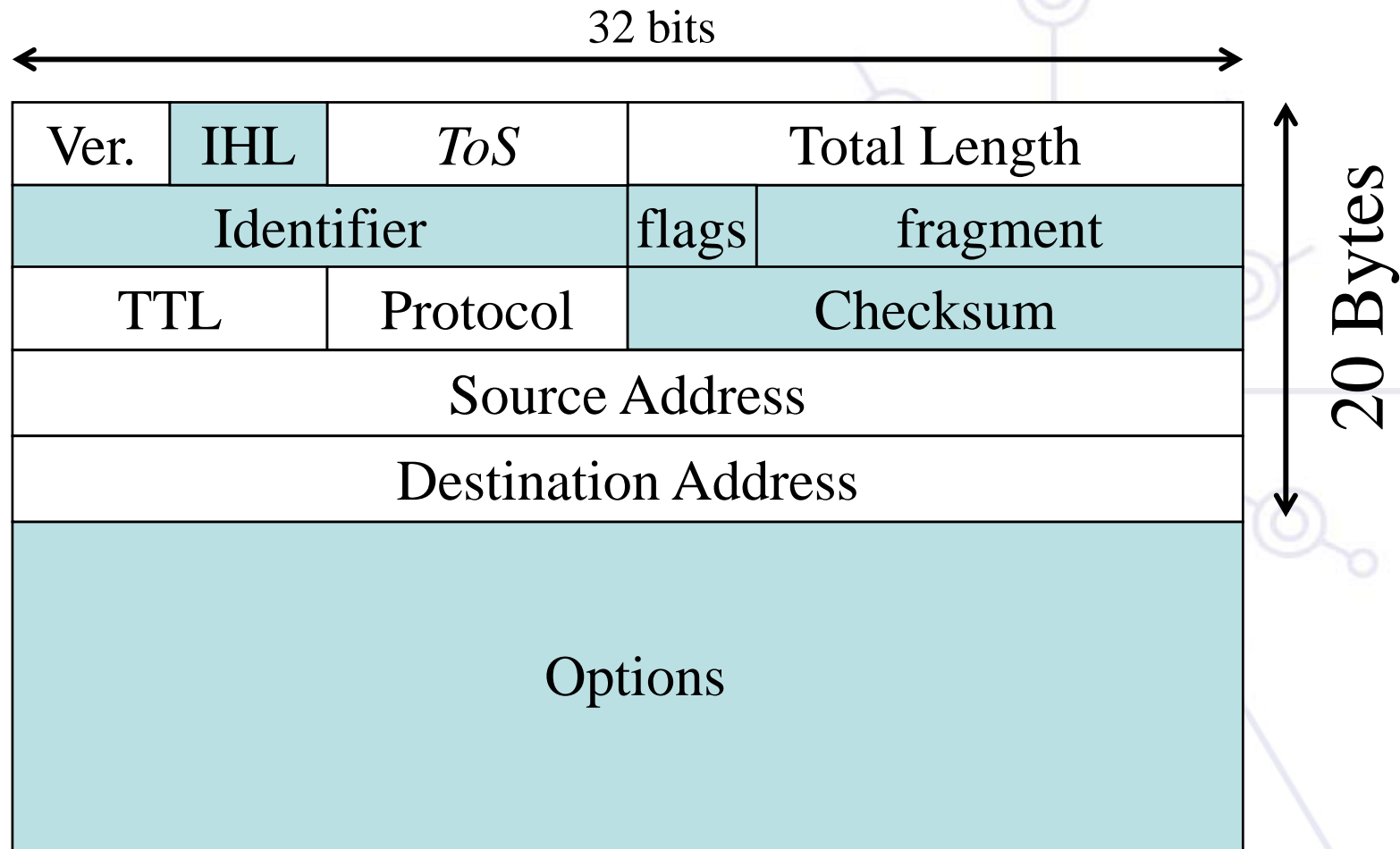

IPv6 Header simplification

32 bits

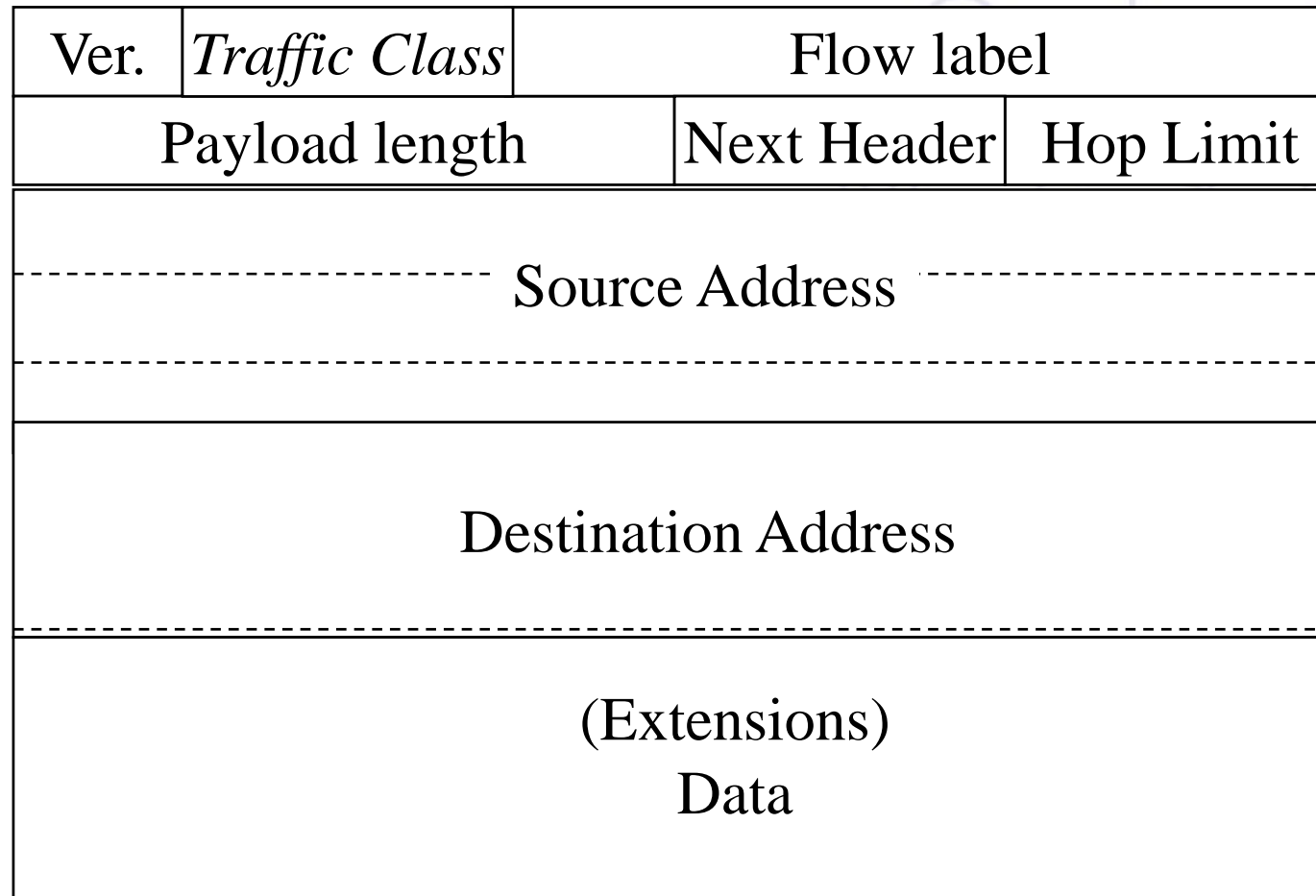

40 Bytes

IPv6 header fields

Version

- 4 bits

Traffic class (*see next slide*)

- 8 bits

Flow label (*see next slide*)

- 20 bits

Payload length

- Use Jumbogram for specific cases (payload = 0)
- 16 bits

Hop limit

- 8 bits

Next header

- 8 bits

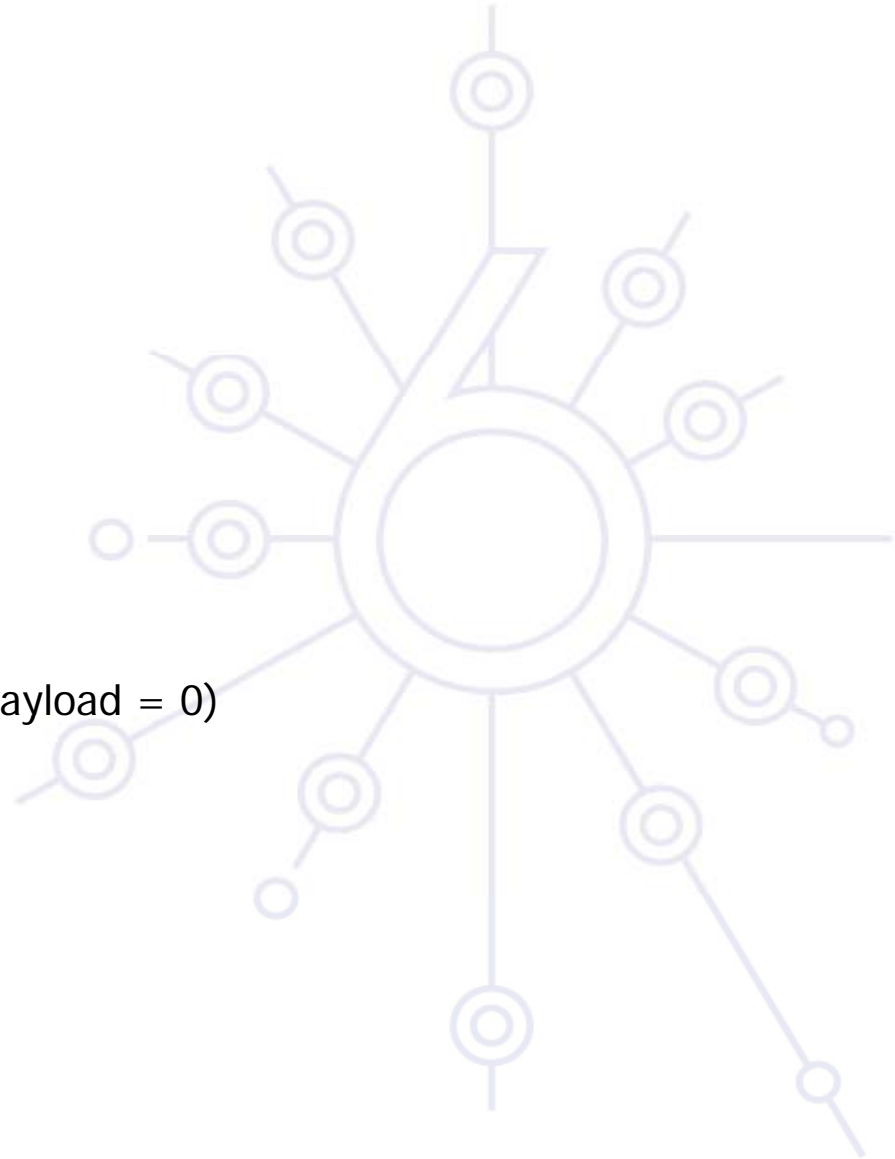

CoS support in IPv6

The Traffic Class field: *used as in IPv4*

- Work done in diffserv wg (closed): RFCs **2474**, 2475, 2597, 3260, ...



CU is Currently Unused (reserved)

The Flow Label field: designed to enable classification of packets belonging to a specific flow

- **A flow** is a sequence of packets that should receive specific non-default handling from the network
- Intuitively: 5-tuple of the same source/destination address/port and transport protocol values
- Without the flow label the classifier must use transport next header value and port numbers
 - Less efficient (need to parse the option headers)
 - May be impossible (fragmentation or IPsec ESP)
- Further info:
 - RFC 3697 (PS)

IPv6: optional Extensions

New “mechanism” replacing IPv4 options

An IPv6 extension :

- Every extension has its own message format
- Is a $n \times 8$ -byte datagram
- Starts with a 1-byte ‘Next Header’ field
 - Pointing to either another extension or a L-4 protocol

Hop-by-hop (jumbogram, router alert)

- Always the first extension
- Analyzed by every router.

Destination

Routing (*loose source routing*)

Fragmentation

Security

- Authentication (AH)
- Encapsulating Security Payload (ESP) : confidentiality

Order is important (RFC 2460)

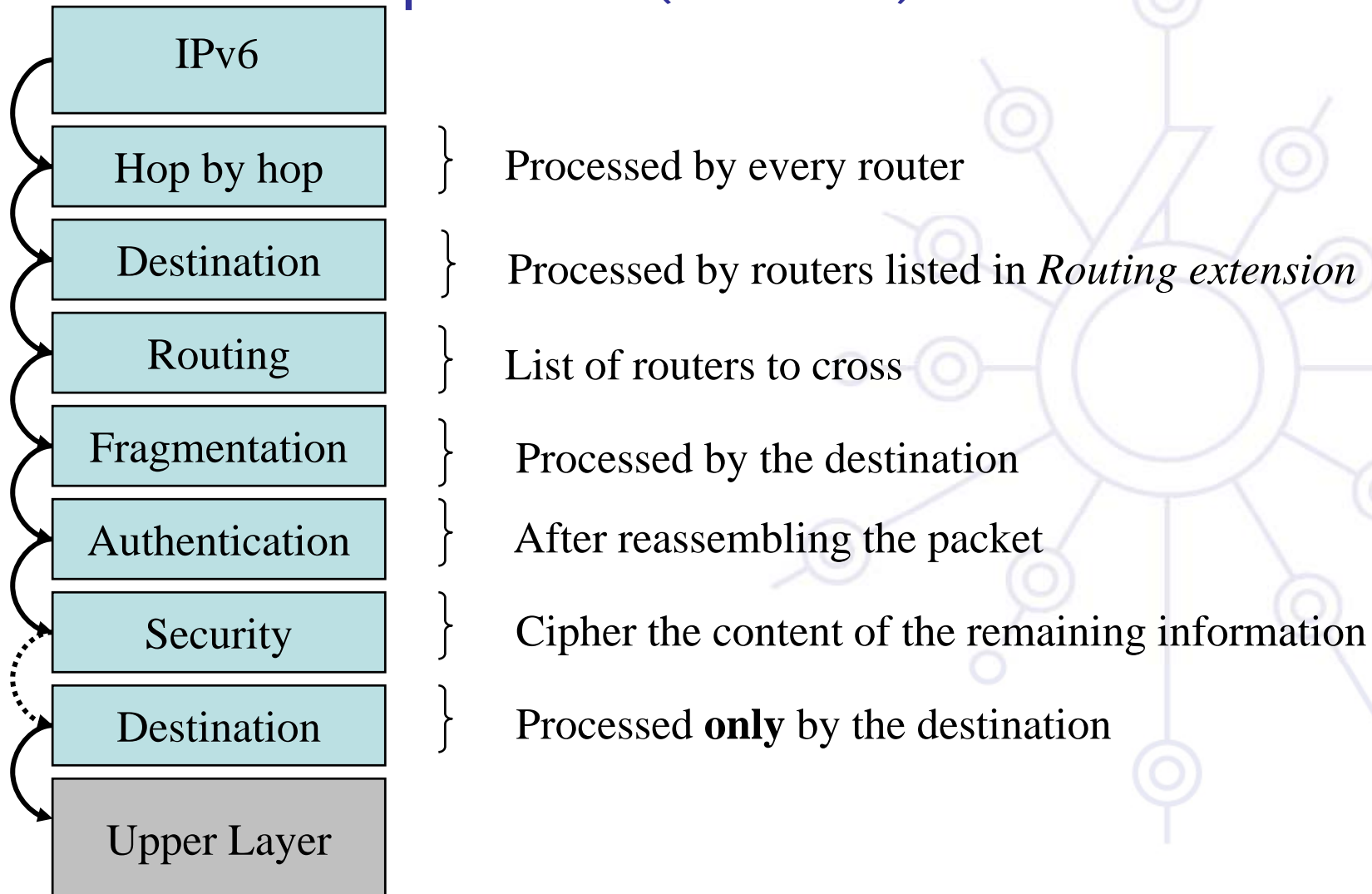

IPv6: Optional headers

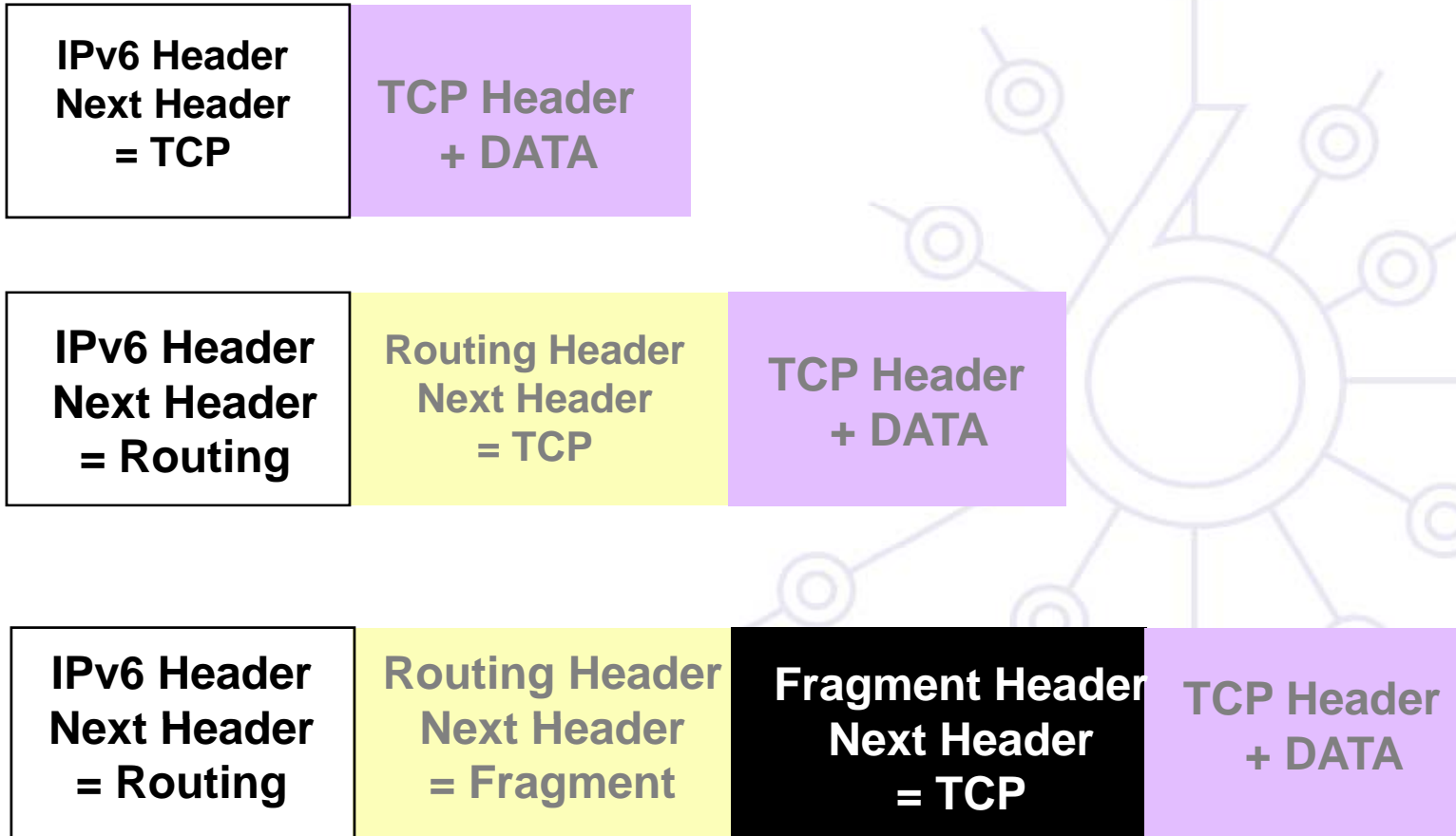

IPv4 header options processing

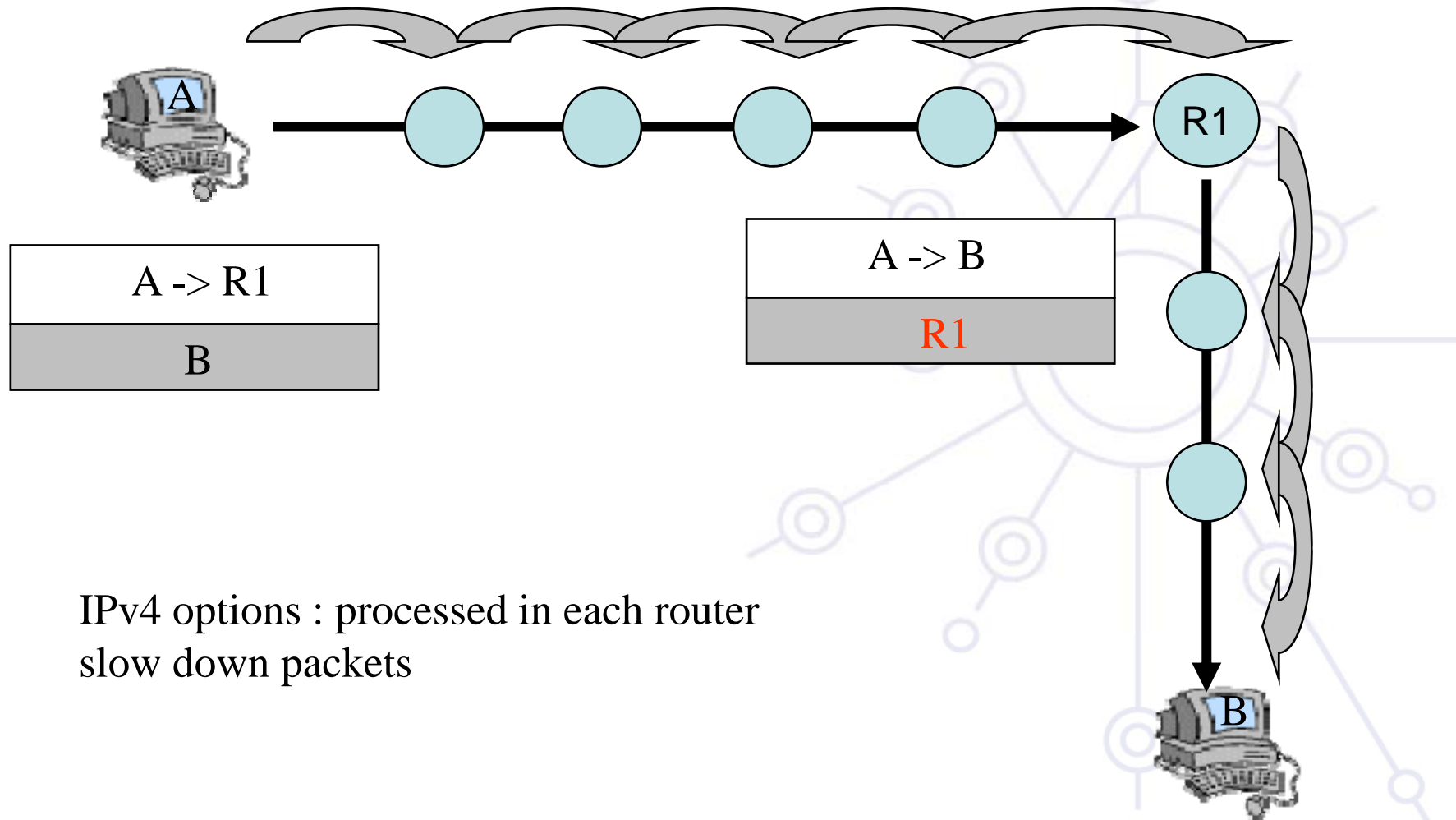

IPv4 options : processed in each router
slow down packets

IPv6 ext. header processing

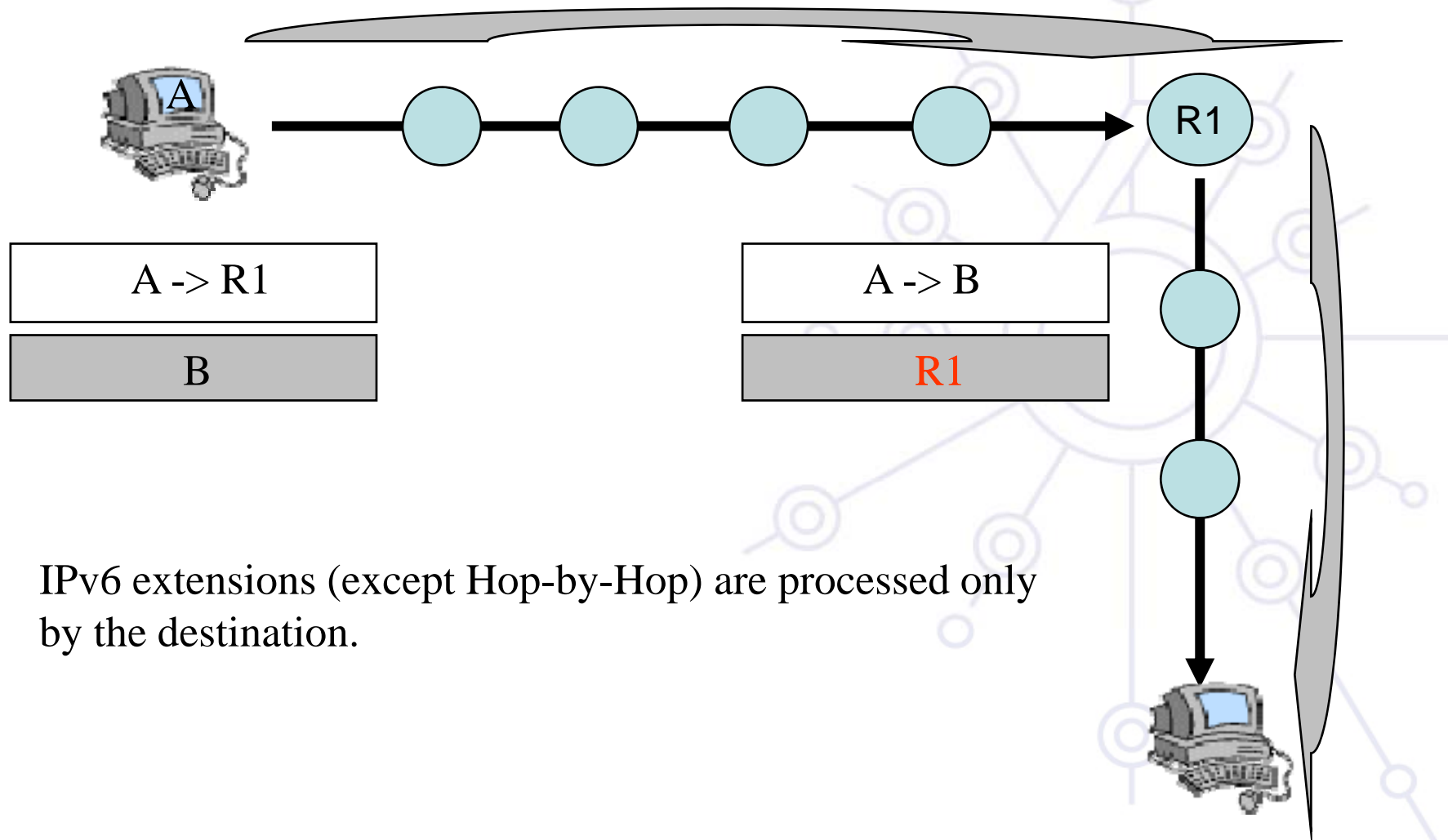

IPv6 extensions (except Hop-by-Hop) are processed only by the destination.

Conclusion

Main changes in IPv6 protocol are within address format and datagram headers

- **A lot of fields in the IPv6 header have disappeared**
 - ⇒ More efficient processing in the (intermediate) routers
- **Optional extensions allow more functionalities (source routing, authentication, ...)**
- **Optional header mechanism allows new options introduction without modifying the protocol**



DEPLOY

Questions ...